

Central University of Karnataka
Aland Road, Kadaganchi, Kalaburgi-585367
Karnataka State, India
Phone 08477-226716, Telefax: 226703
Website: www.cuk.ac.in E-mail purchases@cuk.ac.in

Tender Notification No. 2503/PUR/CUK/2015-16/33

Date: 18.09.2015

LIMITED TENDER NOTIFICATION

The Central University of Karnataka intends to procure Class Room Desks (two seater) as per the specifications mentioned in Annexure-I from the reputed manufacturer / authorized dealers only. The manufacturers or authorized dealers are instructed to submit the tender in sealed envelope for supply of Two Seated Class Room Desks as specified in Annexure-I on the printed letter head of the firm consisting the details as per attached proforma, along with the dealer authorization letter from the main agency, if any on or before **1st October 2015 by 2:00 p.m.** and the tender will be opened on the same day at **3:00 p.m.** in presence of the bidders.

DDs for the tender document cost is **Rs. 1000** (nonrefundable) and EMD **Rs. 25,000/-** shall be drawn on any nationalized bank in favour of Central University of Karnataka, payable at Kalaburagi, should be submitted along with the bid. The Security bid EMD of the unsuccessful bidder will be returned back without interest and the EMD of the successful bidder will be converted into a Security Deposit. Security Deposit will be 10 percent of the price exclusive of taxes. It will be repaid without any interest after the warranty period. Other details of tender are as under:

1) Requirement

The specifications for 2 seater class room desks are given in Annexure - 1 and the quantity is 80 to 100 desks.

2) Eligibility Criteria for bidders:

- a. Bidder should be a reputed manufacturer of furniture items/ authorized suppliers / dealers of reputed furniture manufacturers who are in the business of manufacturing / selling furniture items for more than 3 years with an annual turnover of more than Rs. 50 lakhs in furniture items during the last 2 years.
- b. The authorized dealers/manufacturer must have successfully executed at least three supplies of similar nature to Central / State Government Educational Institutions. Copies of the purchase order should be enclosed.
- e) The tenderers must have PAN / TIN No. and VAT No. and must submit legible attested copies of PAN/TIN No. and VAT no. with Bid. Bid without these documents will be rejected.
- f) Self attested copies of last two years returns of Income tax, and VAT/ CST should be enclosed.
- g) The tenderer must give warranty of at least 3 years for the desks supplied and should be able to rectify / attend the complaints within 3 days of the receipt of complaint excluding Saturday and Sunday during warranty period.
- h) The tenderer should have fulfilled all legal / statutory requirement to carry on the business of manufacturing / selling furniture.

3) Terms and Conditions:

1. Unit prices are to be quoted both in figures and in words. In case of a discrepancy, that quoted in words / figures, lower will be taken as valid.
2. The bidder should be a reputed firm and brief profile of the firm and all the items quoted should be supplied with the technical bids (catalog). Incomplete Bids in any respect are liable to be rejected.
3. The bidder must meet the specifications given in **Annexure – I**.
4. The bidders are advised to bring one piece of sample desk for bid opening meeting.

5. The firm should provide the telephone number and e-mail ID on the envelope.
6. 90% payment of the will be made on receipt, acceptance and satisfactory supply report furnished by the concerned department.
7. All the furniture items should be guaranteed for a period of three years from the date of supply. In case any fault is observed during warrantee to be repaired / replace the item free of cost.
8. The quantity included in the bid can be increased or decreased at the discretion of the Competent Authority of the Central University of Karnataka, Gulbarga.
9. The supply of said items has to be made within a period of four weeks from the date the issue of Purchase Order by the University. In case firm fails to supply the said items in the specific time, 0.5% cost of the whole supply for every week as late supply will be deducted from the bill to the maximum of 10% after which the order will remain cancelled and Earnest Money Deposited will be forfeited.
10. Item offered in the tender may be re-ordered at the same rate, terms and conditions within a period of twelve months / one year.
11. All pages of the tender document are to be signed and stamped by the tendering firm and to be attached along with the bids, that the firm has accepted all the terms and conditions.
12. The price quoted should be FOR by including all the installation charges, transportation charges, taxes etc. and to indicate the taxes separately.
13. The University reserves all the right to reject or accept any tender without assigning any reason or cancel or withdraw the tender notice.
14. In case of any dispute, Gulbarga will be the Jurisdiction. The Registrar, Central University of Karnataka, shall decide the issue and his decision will be final and shall be the binding on the parties.

Sd./
Registrar

Annexure I – Specifications

1. Description: Two students sitting desk cum bench.
2. Dimensions : Width : 3.5 Feet, Height 2.5 Feet, Depth : 3 Feet

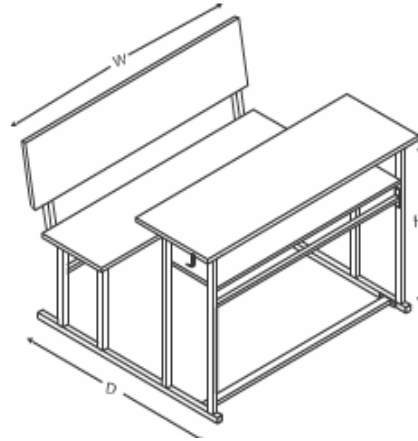

3. Top: The panels are made from 18 mm thk Pre-Laminated Boards with PVC edge banding on all sides.
4. Understructure: Made of 25.4 x 25.4 mm x1.2 mm thk powder coated ERW tubes at base which are welded to the desk and seat supports that are made of 1.0 mm thk powder coated MS 'C' sections. Stiffeners that are provided between the 2 vertical frames at base and back of seat are made from 25.4 x25.4 x1.2 mm thk powder coated ERW tubes. The tubes are closed with plastic caps. Additional horizontal supports of 1.5 mm thk powder coated MS 'C' sections are placed below the desk and seat to add to the rigidity of the structure. The storage shelf is made from 0.6 mm thk powder coated MS sheet which is affixed below the desk top. Hooks are provided on either sides of the vertical frame of the desk, for hanging bags/bottles. They are made from 6.0 mm dia MS rods. The understructure is assembled using M5 taptite screws. Level adjustors are provided to take care of unevenness in floor.
5. Model for colour and shape:



Central University of Karnataka

Limited Tender Enquiry for Supply of Classroom Desks

Technical Bid

SL. No	Enclosures	Enclosed (Yes/No)
1)	Name of Firm:	
2)	Nature of ownership (Proprietary/Partnership/Pvt. Ltd. Company/Public Ltd. Co. et.)	
3)	Tender Document Fee (DD should be enclosed)	
4)	EMD (DD should be enclosed)	
5)	Self attested copy of PAN (PAN No.....)	
6)	Self attested copy of VAT/CST Certificate CST No.....TIN No.....	
7)	Satisfactory Performance of supply of desks for last 2 year from at least Three organization/Institution of repute.	
8)	The Bidder must enclose the Authorization letter for supplying specified Machinery <u>(mandatory)</u>	
9)	The Company should be at least 03 years old and turnover of the company should be 50 Lakhs per annum for last 2 years. Enclose audited financial statement of last two years.	
10)	The Vendor should have executed at least 3 similar supply orders. Enclose self attested copies of purchase orders.	

Authorized Signatory

Seal

Date:

Place :

Central University of Karnataka

Limited Tender Enquiry for Supply of Classroom Desks

Financial Bid

Sl.no	Particulars	Qty.	Price inclusive of transportation and installation charges
1	Two studens sitting desk-cum-bench as per the specifications given in Annexure 1 of the Tender Notifcaiton.	One	
			Taxes
			Grand Total

Rupees in Words:.....

Authorized Signatory

Seal

Date:

Place :

Content for Envelope

Submission of Bid for Supply of Class Room Desks

**To,
The Registrar
Central University of Karnataka
Aland Road, Kadaganchi, KALABURAGI - 585367
Karnataka State**

From:

Address with phone no. and Mail. Id of the bidder